

Fully Fabricated Stainless Steel DP1 Planter
with Stainless Steel 2B Base.
Also with 4 x Stainless Steel Adjustable Feet.

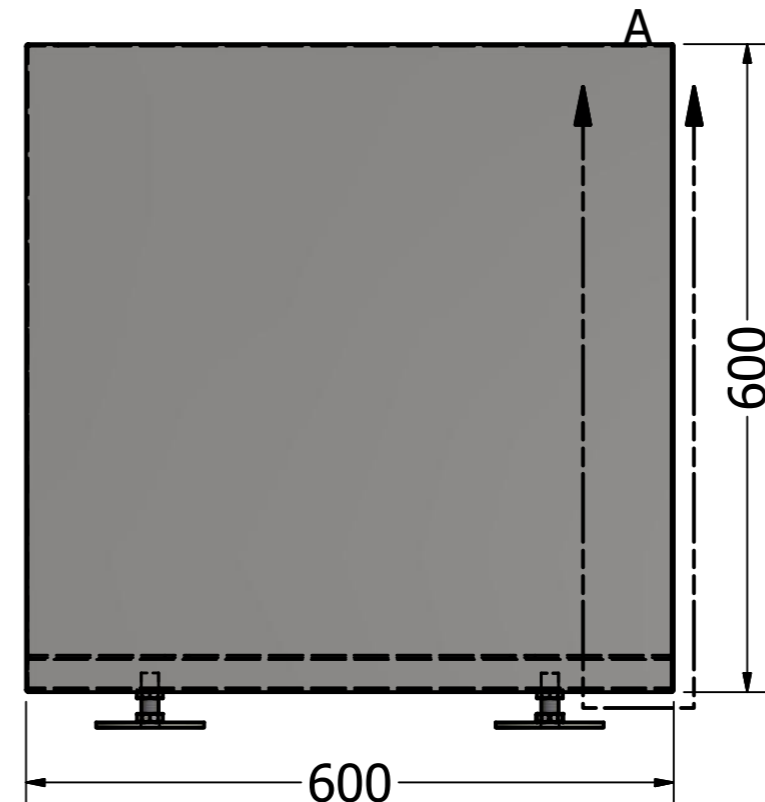

DETAIL A
SCALE 1 / 3

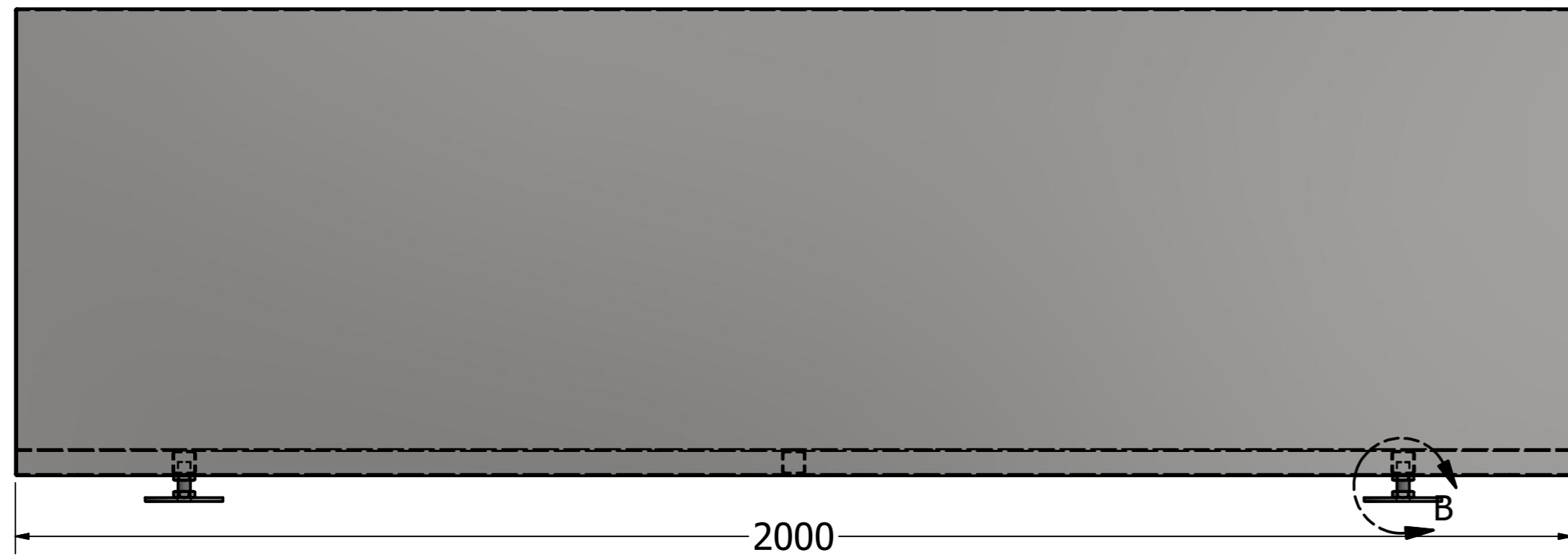
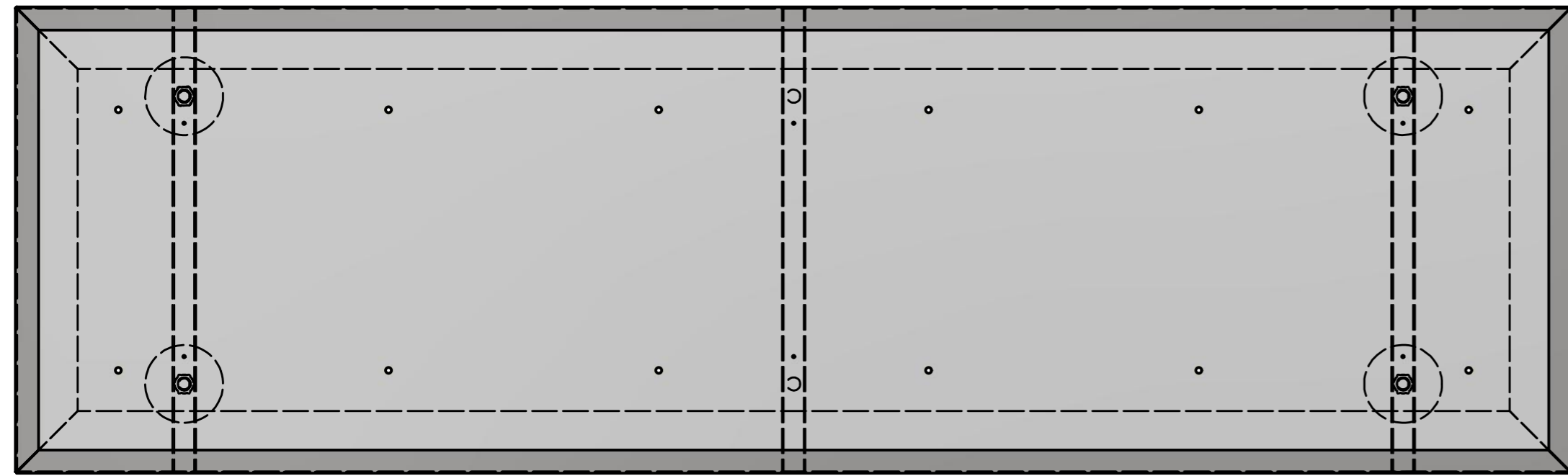
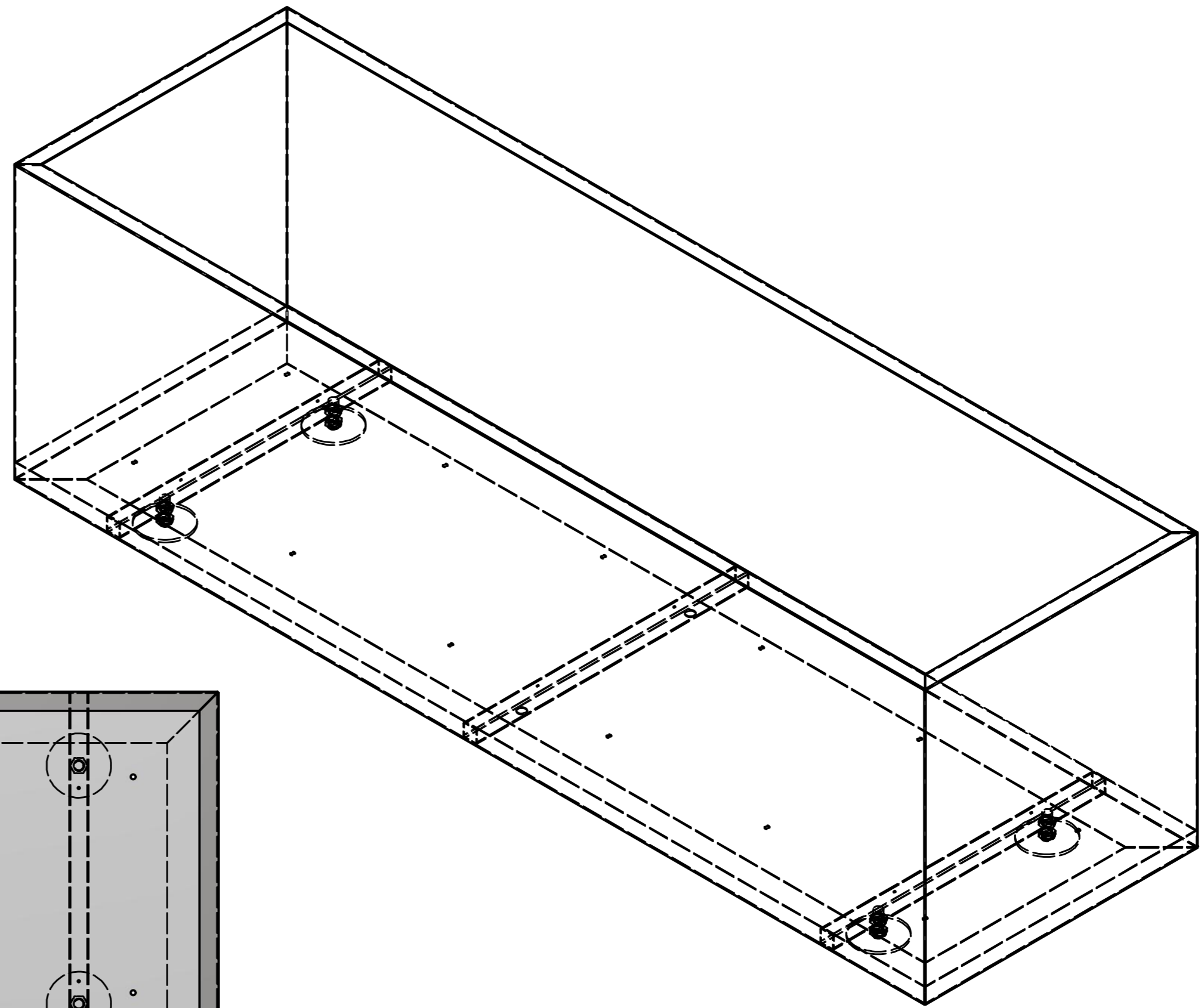
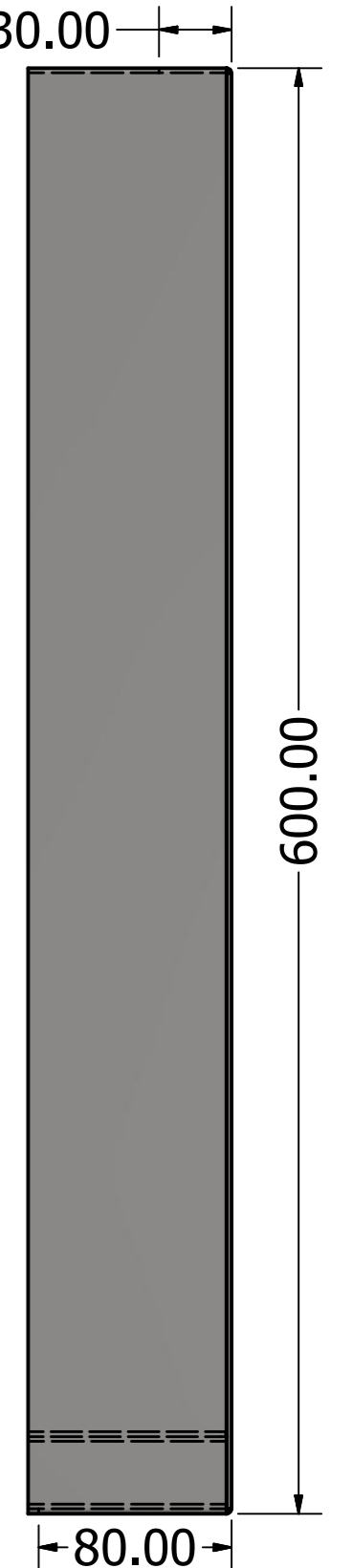

DETAIL B
SCALE 1 / 2
ADJUSTABLE
FEET

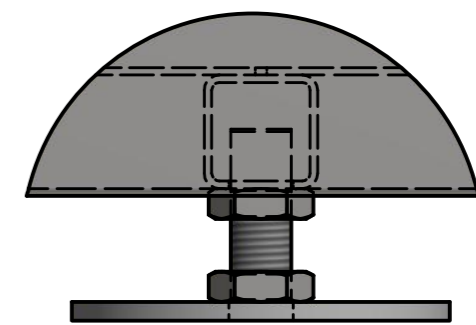

URBAN STREET DESIGNS LTD.
ST MARYS STREET, NELSON, BB9 7BA.
TEL: +44 (0)1282 507 656
EMAIL: sales@urbanstreetdesigns.co.uk
WEB PAGE: www.urbanstreetdesigns.co.uk

IF IN DOUBT ASK!

DRAWN BY: Liz
DATE: 15/03/2017
SCALE: 1 / 7
PAGE SIZE: A2 PAGE No: 1 / 1

REPORT ALL ERRORS TO DRAWING OFFICE
3RD ANGLE PROJECTION
ALL DIMENSIONS ARE IN MILLIMETRES

URBAN STREET DESIGNS LTD
2015 © Urban Street Designs Ltd All Rights Reserved.
USD. CONFIDENTIAL AND PROPRIETARY. ALL RIGHTS RESERVED. This document (and the information it contains) are the property of USD. By accepting it into your possession, you agree that you will keep this document, and all information contained herein, in strictest confidence, and will not copy, retransmit, use (except solely for the benefit of USD), sell, lend or otherwise dispose of, directly or indirectly, without the express written permission of USD, and this document will be returned to USD immediately upon request.

MATERIAL + SPEC: 304 S/S DP1
FINISH: DP1
DESCRIPTION/NOTES:

DRAWING NUMBER: Free Standing Planter
PART NUMBER: Free Standing Planter with Adjustable Feet - website version
CUSTOMER REF. DWG No: NA
REV: A